

# Ray EVO Set ZW



## Podstawowe dane techniczne / Basic technical data:

Zasilanie / Feed AC 230V 50/60Hz  
 Źródło światła / Light source LED  
 CRI / Color rendering index CR90  
 Moc / Power 14W-65W

## Dotyczy opraw / Applies to frames:

<u>RAY EVO SET - LIGHTLINE 590 LP ZW   14W</u>	<u>RAY EVO SET - LIGHTLINE 590 HP ZW   27W</u>
On-Off   5.3476	On-Off   5.3488
Switch   5.3477	Switch   5.3489
DALI   5.3478	DALI   5.3490
<u>RAY EVO SET - LIGHTLINE 870 LP ZW   20W</u>	<u>RAY EVO SET - LIGHTLINE 870 HP ZW   39W</u>
On-Off   5.3479	On-Off   5.3491
Switch   5.3480	Switch   5.3492
DALI   5.3481	DALI   5.3493
<u>RAY EVO SET - LIGHTLINE 1150 LP ZW   27W</u>	<u>RAY EVO SET - LIGHTLINE 1150 HP ZW   53W</u>
On-Off   5.3482	On-Off   5.3494
Switch   5.3483	Switch   5.3495
DALI   5.3484	DALI   5.3496
<u>RAY EVO SET - LIGHTLINE 1430 LP ZW   33W</u>	<u>RAY EVO SET - LIGHTLINE 1430 HP ZW   65W</u>
On-Off   5.3485	On-Off   5.3497
Switch   5.3486	Switch   5.3498
DALI   5.3487	DALI   5.3499
<u>RAY EVO SET - SHIFT IN 590 ZW   19W</u>	<u>RAY EVO SET - SHIFT IN 1150 ZW   36W</u>
On-Off   5.3500	On-Off   5.3506
Switch   5.3501	Switch   5.3507
DALI   5.3502	DALI   5.3508
<u>RAY EVO SET - SHIFT IN 870 ZW   27W</u>	<u>RAY EVO SET - SHIFT IN 1430 ZW   44W</u>
On-Off   5.3503	On-Off   5.3509
Switch   5.3504	Switch   5.3510
DALI   5.3505	DALI   5.3511



Ten produkt zawiera źródła światła o klasie efektywności energetycznej:  
 This product contains a light sources of energy efficiency class:



Ten produkt zawiera źródła światła o klasie efektywności energetycznej:  
 This product contains a light sources of energy efficiency class:



Light source (LED only) contained in the luminaire replaceable only by a professional  
 Źródło światła (tylko LED) umieszczone w oprawie powinno być wymieniane tylko przez wykwalifikowaną osobę

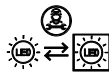

Control gear contained in the luminaire replaceable only by a professional  
 Zasilacz umieszczony w oprawie powinien być wymieniany tylko przez wykwalifikowaną osobę

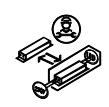

**UWAGA !** Nie podłączać oprawy oświetleniowej do zasilacza LED przy włączonym zasilaniu!! Podłączenie oprawy oświetleniowej do zasilacza przy włączonym zasilaniu grozi uszkodzeniem modułu LED i utratą gwarancji.

**NOTE !** Do not connect the lighting fixture to the LED driver with the power on !! Connecting the lighting fitting to the LED driver with the power switched on may damage the LED module and void the warranty.

**LABRA Sp. z o.o.**

biuro@labra.pl / export@labra.pl  
 -48 500 175 552 / www.labra.pl

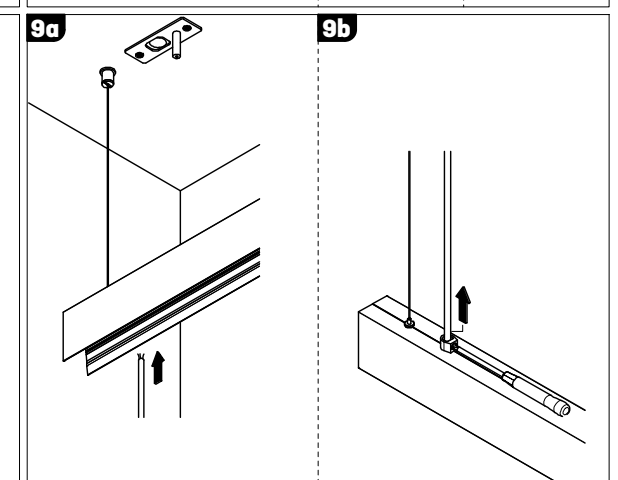
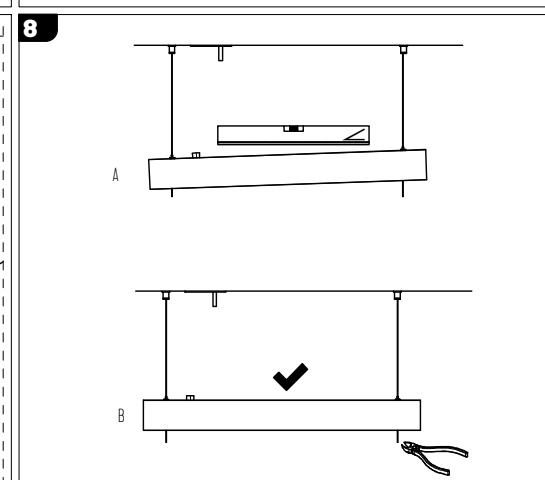
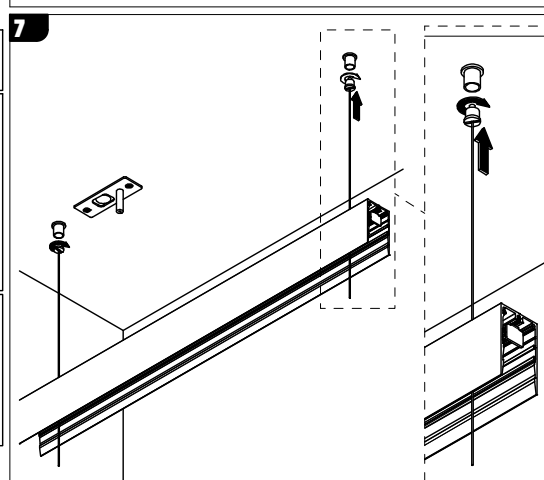
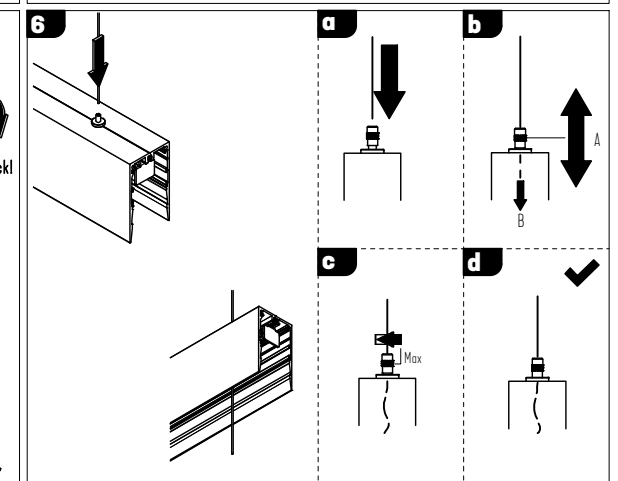
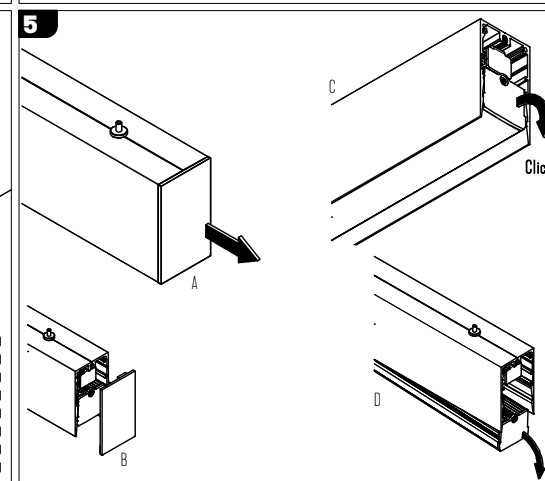
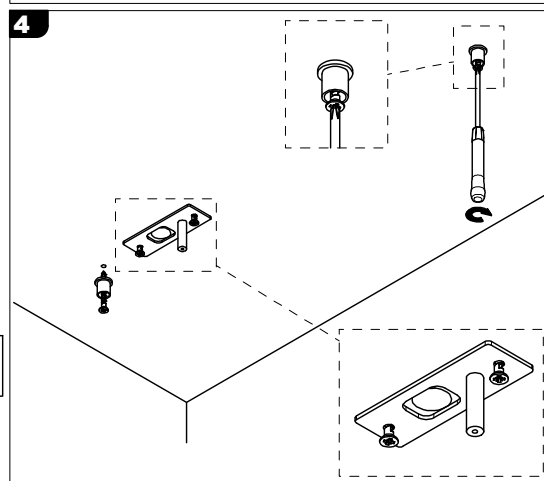
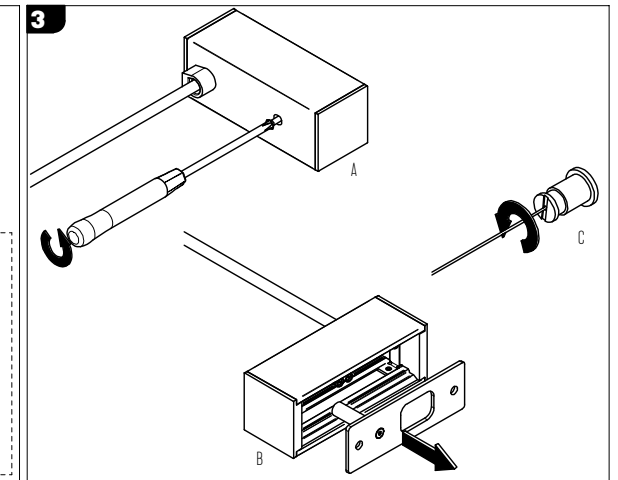
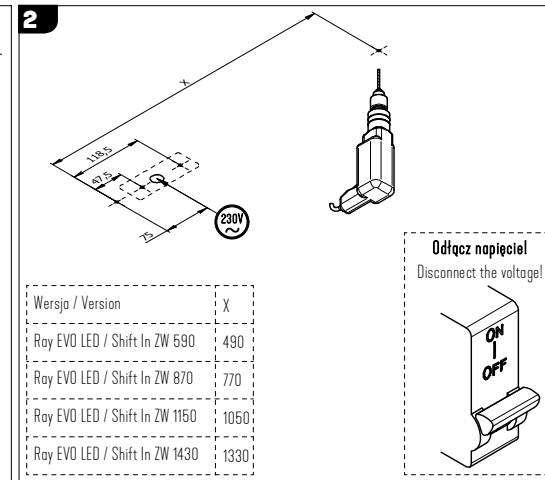
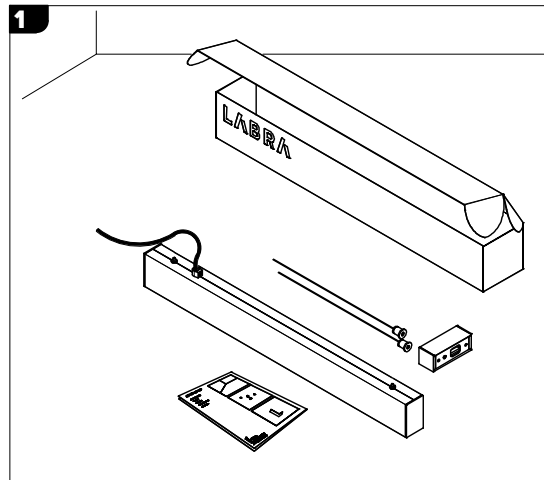

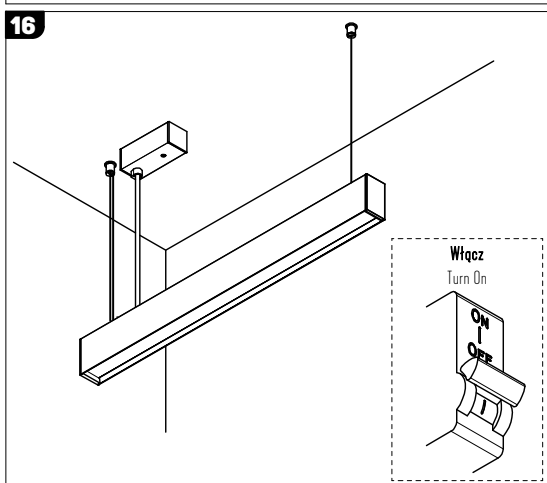
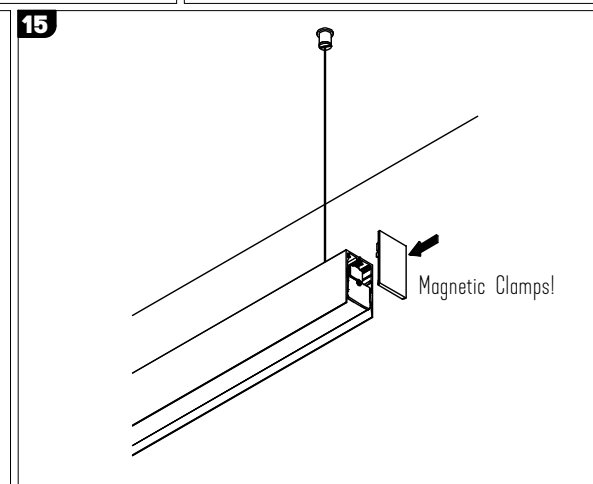
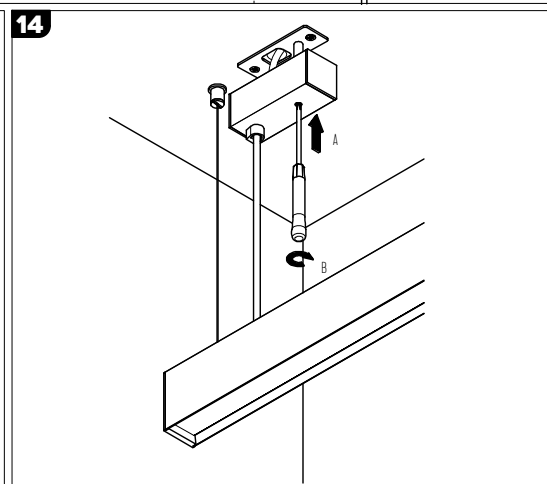
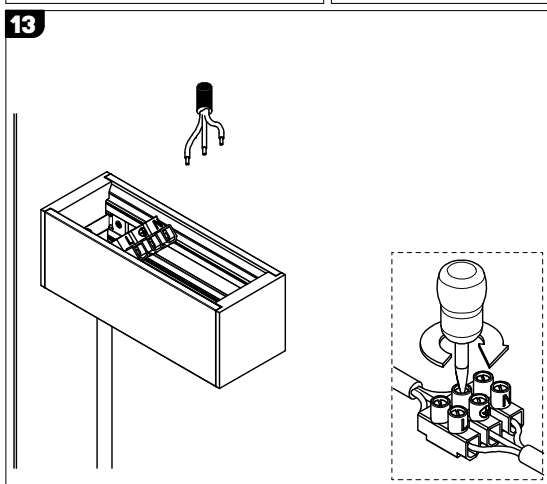
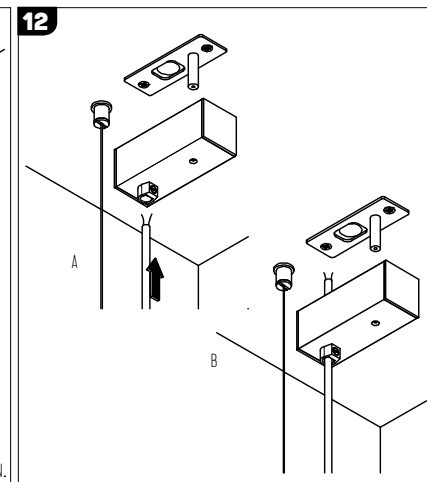
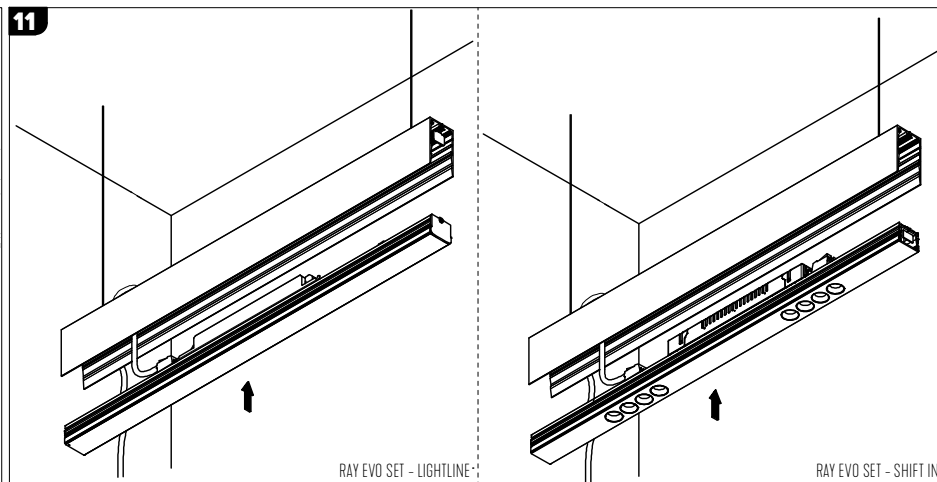
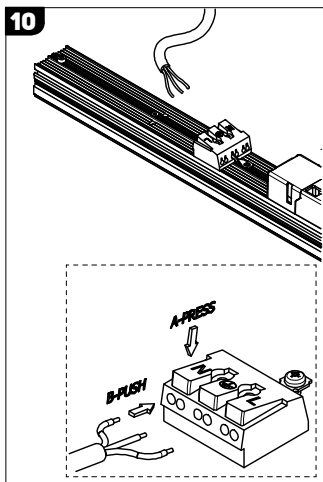

Light source (LED only) contained in the luminaire replaceable only by a professional  
 Źródło światła (tylko LED) umieszczone w oprawie powinno być wymieniane tylko przez wykwalifikowaną osobę

Control gear contained in the luminaire replaceable only by a professional  
 Zasilacz umieszczony w oprawie powinien być wymieniany tylko przez wykwalifikowaną osobę

**UWAGA 1** : Nie podłączać oprawy oświetleniowej do zasilacza LED przy włączonym zasilaniu!!! Podłączenie oprawy oświetleniowej do zasilacza przy włączonym zasilaniu grozi uszkodzeniem modułu LED i utratą gwarancji.

**NOTE 1** : Do not connect the lighting fixture to the LED driver with the power on !!! Connecting the lighting fitting to the LED driver with the power switched on may damage the LED module and void the warranty.